

11

## Netter High Frequency Electric External Vibrators Series NEG/NEH



- High centrifugal force
- High power reserves for constant rotational speed
- Low unit weight
- High operational safety
- Tropical insulation by vacuum impregnation
- Protection class IP 66
- Frequency 3.000 min<sup>-1</sup> or 6.000 min<sup>-1</sup>
- Models in the NEH series can be easily repositioned using quick release brackets NVH





# NetterVibration



## Netter High Frequency Electric External Vibrators Series NEG/NEH

Type	Frequency [min <sup>-1</sup> ]	Centrifugal Force [N]	Working Moment [cmkg]	Power [w]	Current Consumption 42 V, 200 Hz [A]	Current Consumption 250 V, 200 Hz [A]	Current Consumption 230 V, 50 Hz [A]	Current Consumption 400 V, 50 Hz [A]	Weight [kg]
NEG 756	6.000	7.500	3,8	650	9,0	1,6	-	-	16
NEG 1206	6.000	12.000	6,1	930	12,8	2,3	-	-	23
NEG 1606	6.000	16.000	8,1	1.020	14,0	2,6	-	-	23
NEH 756	6.000	7.500	3,8	650	9,0	1,6	-	-	14,5
NEH 1206	6.000	12.000	6,1	930	12,8	2,3	-	-	22
NEH 1606	6.000	16.000	8,1	1.020	14,0	2,6	-	-	22
NEH 603	3.000	6.000	12,2	280	-	-	1,0	0,6	15
NEH 903	3.000	9.000	18,2	900	-	-	2,4	1,4	24,5
NEH 1403	3.000	14.000	28,4	920	-	-	2,7	1,5	25

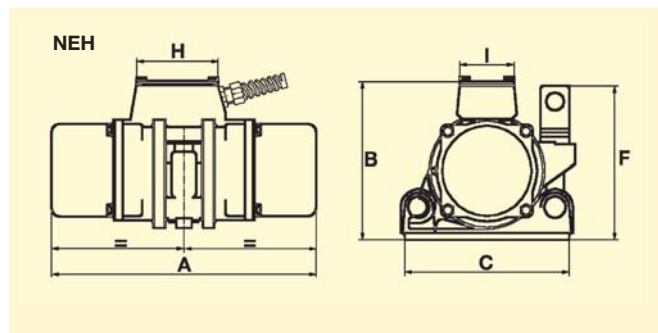
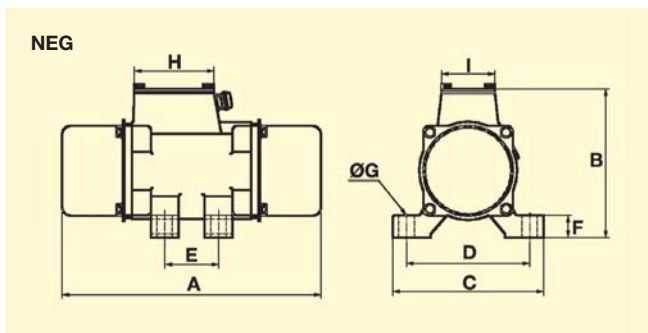

Type	A [mm]	B [mm]	C [mm]	D [mm]	E [mm]	F [mm]	G [mm]	H [mm]	I [mm]	Quick release bracket
NEG 756	270	163	166	130	50	26	15	102	68	-
NEG 1206	370	211	216	176	77	32	21	114	76	-
NEG 1606	370	211	216	176	77	32	21	114	76	-
NEH 756	270	170	165	-	-	164	-	82	60	NVH 1
NEH 1206	370	220	230	-	-	214	-	114	76	NVH 4
NEH 1606	370	220	230	-	-	214	-	114	76	NVH 4
NEH 603	270	170	165	-	-	164	-	82	60	NVH 1
NEH 903	370	220	230	-	-	214	-	114	76	NVH 4
NEH 1403	370	220	230	-	-	214	-	114	76	NVH 4

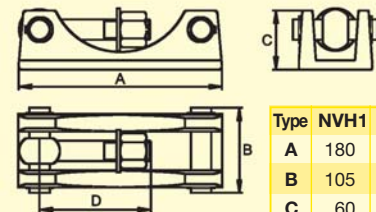

Type	NVH1	NVH4
A	180	240
B	105	100
C	60	70
D	100	130

Dimensions of NVH 1 and NVH 4 in mm

### Applications

The Netter series NEG/NEH high frequency electric external vibrators were specially developed for concrete compaction in tunnel formworks and in moulds used in plants which manufacture pre-fabricated parts. The nominal rotational speed of 6.000 min<sup>-1</sup> and robust construction satisfy the requirements of the construction industry.

### Construction and Working Principle

Electric external vibrators are unbalance motors which operate according to the short circuit rotor principle. Adjustable unbalances located at each end of the shaft create a non-directional, sinus-shaped vibration at the frequency of the respective rotational speed. The NEG series differs from the NEH series in their type of attachment. NEG vibrators are mounted using Netter series NBS attachment sets. NEH vibrators are attached using Netter series NVH quick-release brackets. This allows easy repositioning of the units.

All NEG/NEH are suitable for operation with Netter frequency and voltage converters, without any restriction.

NetterVibration has a worldwide network of experienced application engineers and field representatives. We would be pleased to offer advice on site and to help optimise your applications using vibration technology.

**Netter provides solutions. Consult our experienced application technicians.**

### Netter GmbH

#### Germany

Fritz-Ullmann-Str. 9  
55252 Mainz-Kastel  
Tel. +49 6134 2901-0  
Fax +49 6134 2901-33

#### Switzerland

Erlenweg 4  
4310 Rheinfelden  
Tel. +41 61 8316200  
Fax +41 61 8311291

#### Poland

Al. W. Korfantego 195/17  
40-153 Katowice  
Tel. +48 32 2050947  
Fax +48 32 2051572

www.**NetterVibration.com**  
info@**NetterVibration.com**